

## Bearing system with noise reduction TSS

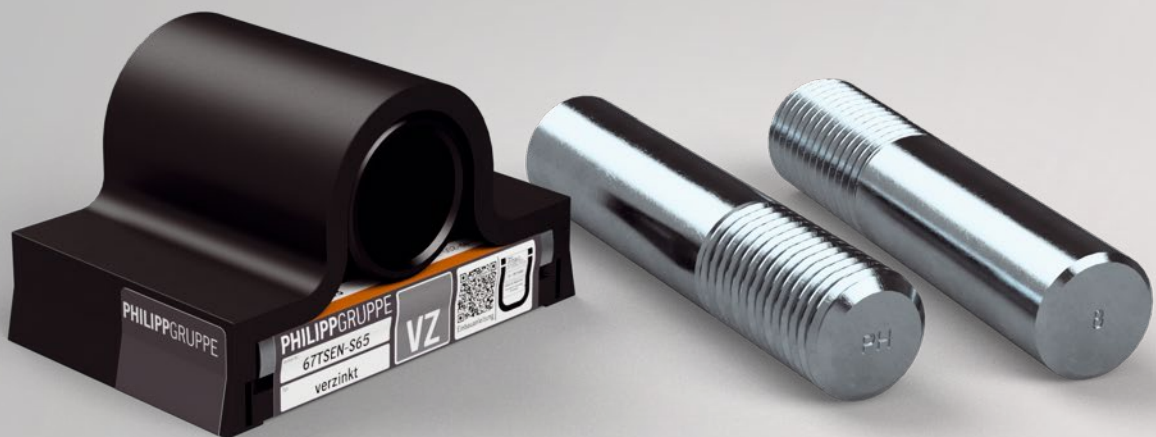

### Installation Instruction

# Our products from the division BUILDING SOLUTIONS

## SERVICES

- » On-site tests -> we ensure that your requirements are properly covered by our planning.
- » Test reports -> for your safety and documentation.
- » Trainings -> the knowledge of your employees from planning and production is enhanced by our experts on site, online or via webinar.
- » Planning support -> latest design software, planning documents, CAD data and much more can be downloaded any time from [www.philipp-group.de](http://www.philipp-group.de).

## HIGH DEMANDS ON PRODUCT SAFETY AND PRACTICALITY

- » Close cooperation with notified bodies and - if necessary - approval of our solutions.

## TECHNICAL DEPARTMENT

- » Our expert-team will support you at any time during your planning phase with detailed advice.

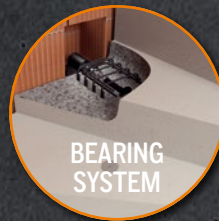
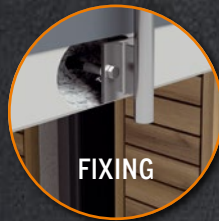
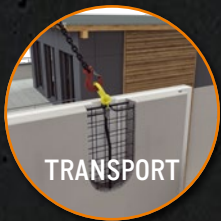

## CONTENT

<b>OVERVIEW BEARING SYSTEMS WITH NOISE REDUCTION</b>	Page	4
<b>PRODUCT CHARACTERISTICS OVERVIEW</b>	Page	6
<b>THE BEARING SYSTEM WITH NOISE REDUCTION (TSS SYSTEM)</b>	Page	8
System description	Page	8
System overview	Page	9
<b>INSTALLATION PARTS</b>	Page	10
Bearing element	Page	10
Threaded bolt	Page	10
<b>PARTS SET IN CONCRETE</b>	Page	11
Threaded anchors	Page	11
<b>INSTALLATION INSTRUCTIONS</b>	Page	12
Installation options	Page	12
Element dimensions	Page	13
Calculation of the bolt length	Page	13
<b>DESIGN / BEARING CAPACITIES OF THE SYSTEM</b>	Page	14
<b>NOISE REDUCTION</b>	Page	15
Impact sound reduction data	Page	15
Spring stiffnesses	Page	15
<b>REINFORCEMENT</b>	Page	16
Reinforcement	Page	16
<b>BENDING OF THREADED ANCHORS</b>	Page	17
<b>FIRE PROTECTION PLATE</b>	Page	18
<b>INSTALLATION AND ADJUSTMENT OF THE BEARING SYSTEM WITH NOISE REDUCTION TSS</b>	Page	20
Installation in the precast concrete unit	Page	21
Installation of the bearing element	Page	22

# Noise reduction technology

## ISODORN HQW®

For the decoupling of (spiral) staircases and landings as well as loggias and access balconies, the ISODORN HQW® can be used universally and without further brackets in staircases of any design. The system is suitable for vertical shear forces and can be extended by additional components such as height adjustment, tie bar, increased mounting distances up to 120 mm and much more.



## TREDO

The TreDo dowel is a compact solution for acoustic decoupling of landings and flights of stairs. It is the combination of a simple shear dowel and versatile bearing options convincing with good sound insulation as well as a wide range of applications.



## DOWEL PD

On the one hand the Dowel PD is used to secure the structural position of concrete elements and on the other hand as sound decoupling at the bottom of a staircase. The dowel can be used in prefabricated or in-situ concrete staircases and is available in a galvanised and stainless steel version.

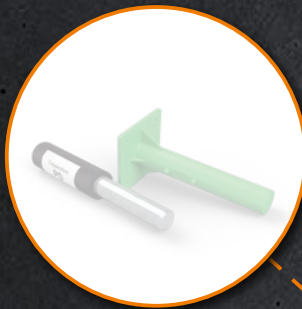

## STAIR ANGLE TYPE PD-H

Stair case angle is used to secure the structural position of concrete elements that are to be decoupled acoustically. The angles are installed at the base of the stairs to support them against horizontal actions.



## SOUND BOARD NB

The Sound board NB is used for the acoustic decoupling of a stair base or a landing from the floor slab. Here, the board can be easily adapted to different geometric shapes of the stair base by cutting on-site. The actual element to be decoupled can be made of in-situ concrete or as prefabricated element.

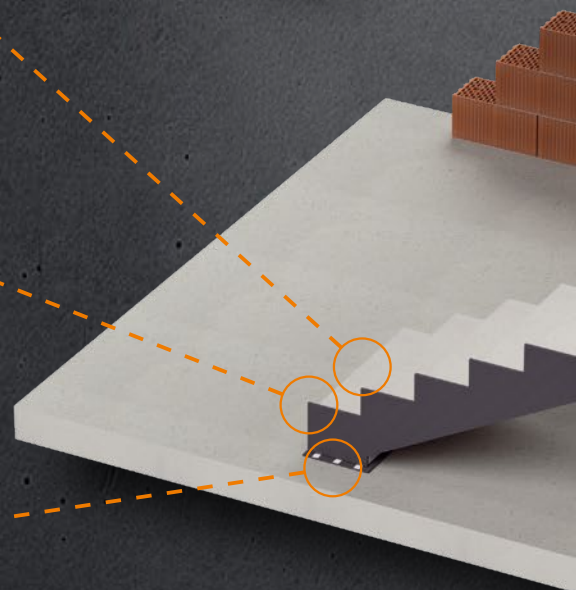



### SOUND BOARD NF

The Sound board NF is used for the acoustic decoupling of stair cases resp. landings with continuous brackets. All concrete elements can be made of in-situ concrete or as prefabricated parts. An adaptation of the Sound board NF to different geometric shapes of the concrete elements is possible by cutting on-site. The special type NF-VH can also be used to transfer horizontal loads from planned actions.

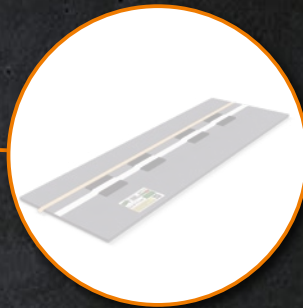

### BEARING SYSTEM WITH NOISE REDUCTION TSS (page 8)

The bearing system with noise reduction is versatile and also suitable for single-flight as well as spiral stair cases. In combination with diverse PHILIPP threaded anchors it is very variable and thus offers numerous possibilities for different stair inclinations.



### SOUND BOARD NL

The Sound board NL is used to create the joint between stairs resp. landings and the staircase walls without acoustic bridges. All concrete elements can be made of in-situ concrete or as prefabricated parts. The boards made of PE foam are self-adhesive with no load-bearing function. An adaptation of the Sound board NL to different geometric shapes of the concrete elements is possible by cutting on-site.



### ISOBOX TSB

The ISOBOX TSB is designed for a wide range of applications and is suitable for use in staircases and in particular for the support of in-situ and precast concrete landings in staircase walls of any type. Here, the system can be individually extended with elastomeric bearings to transfer loads in up to three directions. Only a reinforcement cage within a bracket and no further installation parts requires this type-tested box.

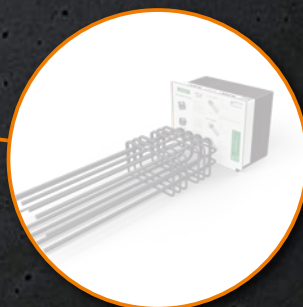

# Noise reduction technology

## PRODUCT CHARACTERISTICS OVERVIEW

	TSS SYSTEM	ISOBOX TSB	ISODORN HQW®	TREDO
				
<b>LOAD DIRECTIONS / DESIGN RESISTANCES</b>				
				
 (+/-) $V_{Rd,max}$ [kN]	+ 38.2	+ 97.0 / - 14.4	± 69.2	± 101.7
 (+/-) $H_{Rd,max}$ [kN]	-	± 35.8	-	± 36.7
 (+/-) $N_{Rd,max}$ [kN]	-	-	-	-
<b>AREA OF APPLICATION</b>				
Precast building	✓	✓	✓	✓
In-situ concrete constructions	✓	✓	✓	✓
Stair type	Straight /spiral	Straight /spiral	Straight /spiral	Straight /spiral
Stair top	✓	✓	✓	✓
Flight of stairs	✓	-	✓	✓
Stair base	✓	✓	✓	✓
Landing	✓	✓	✓	✓
<b>TECHNICAL INFORMATION</b>				
Technical basis	abZ	Type approval	abZ / ETA	ETA
Tests in building acoustics acc. to DIN 7396	✓	✓	✓	✓
Fire resistance class (maybe with fire protection plate, depending on concrete cover)	R120	R120	R120	R120
Material	Elastomeric bearing Steel / stainless steel	Elastomeric bearing Structural steel	Elastomeric bearing Steel / stainless steel	Elastomeric bearing Stainless steel



+ 141.6	+ 141.6	-	-	-
± 8.0	± 8.0	-	-	-
± 8.0	± 8.0	+ 10.0	-	-

✓	✓	✓	✓	✓
✓	✓	✓	✓	✓
Straight /spiral	Straight /spiral	Straight /spiral	Straight /spiral	Straight /spiral
✓	-	-	-	-
-	-	-	-	✓
✓	✓	✓	✓	✓
✓	-	-	-	✓

Type approval	Type approval	Type approval	Type approval	-
✓	✓	-	✓	✓
R120	R120	-	R120	-
PE foam Elastomeric bearing	PE foam Elastomeric bearing	Elastomeric bearing Steel	Elastomeric bearing Steel / stainless steel	PE foam

# Bearing system with noise reduction TSS

## BEARING SYSTEM WITH NOISE REDUCTION (TSS-SYSTEM)

### SYSTEM DESCRIPTION

The TSS system is an approved system (German approval Z-15.7-332) for a sound-decoupled bearing of reinforced concrete elements. It can be used for the bearing of straight stairs (picture 1), spiraled stairs (picture 2 and 3) and landings (picture 4). A bearing of slabs (picture 5), slabs with brackets (for e.g. walls with thermal insulation composite system; picture 6) and beam-

shaped units is also possible. The German national approval considers the use for internal and external concrete elements under predominantly static loads. There are multi-purpose applications for the system because of the different combinations of installation parts and parts set in concrete (picture 7).

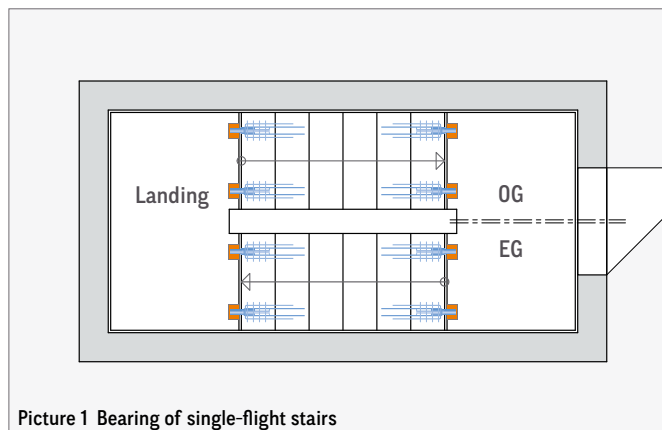

Picture 1 Bearing of single-flight stairs

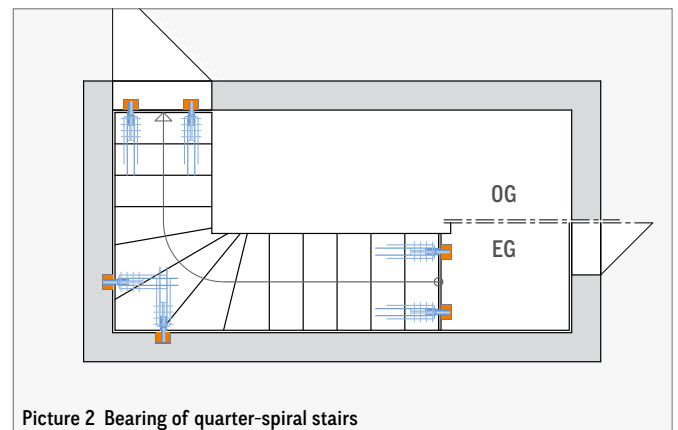

Picture 2 Bearing of quarter-spiral stairs

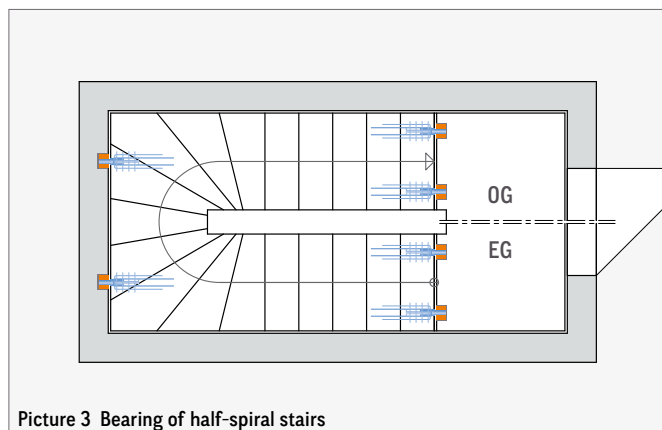

Picture 3 Bearing of half-spiral stairs

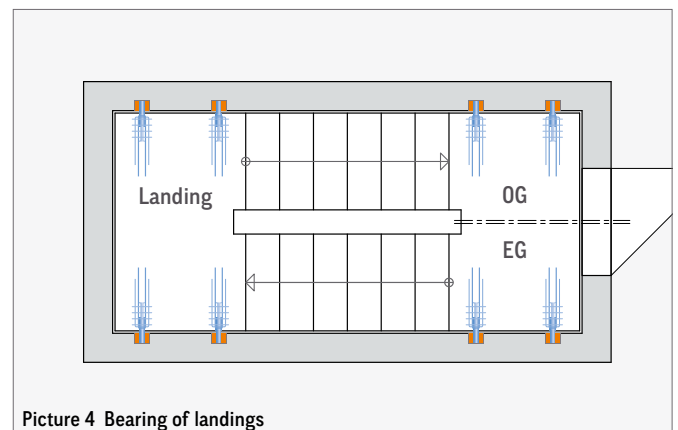

Picture 4 Bearing of landings

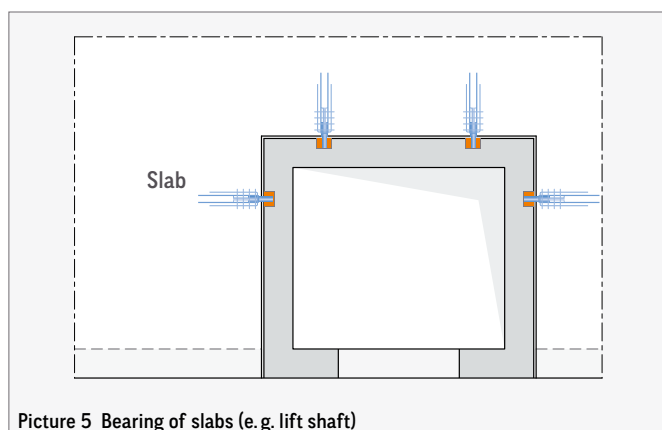

Picture 5 Bearing of slabs (e.g. lift shaft)

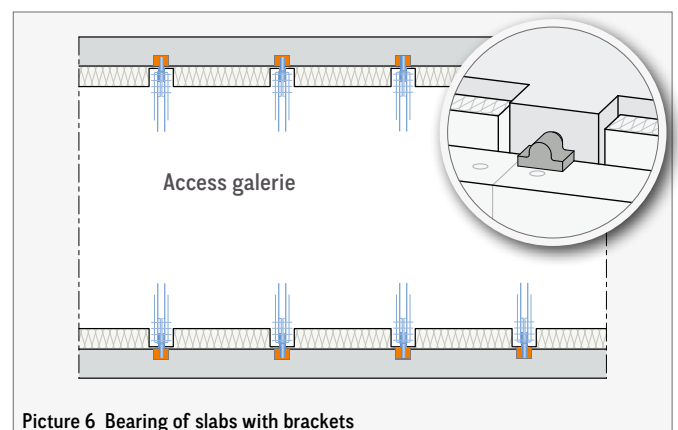

Picture 6 Bearing of slabs with brackets



# BEARING SYSTEM WITH NOISE REDUCTION (TSS-SYSTEM)

## SYSTEM OVERVIEW

The TSS system consists of several single components (picture 7) and is suitable for indoor use (galvanised version) as well as outdoor use (stainless steel version) in concrete elements. Each system contains a threaded anchor, a threaded bolt and the actual bearing element as main components. In turn, the bearing element consists also of several components that are delivered pre-assembled. The bearing element can be supplied with two different elastomeric bearings (Cipremont® / Compression bearing). Find the different noise reduction capacities in table 11.

The load is transferred via the bolt into the steel plate and the elastomeric bearing laying beneath and finally into the load-bearing elements (e.g. masonry or reinforced concrete wall). Multiple anchor types offer the planner the possibility to use the TSS system even with difficult precast constructions.

The threaded anchors have a special round thread RD (with metrical pitch) which is resistant against light dirt. Within the scope of this Installation Instruction, the planner has the option of adapting the bending of straight and angled anchors individually to the geometry (page 17).



### APPROVED BY DIBT (GERMAN APPROVAL)

This Installation Instruction provides necessary technical information. In all cases, the requirements of the German national approval must be considered!

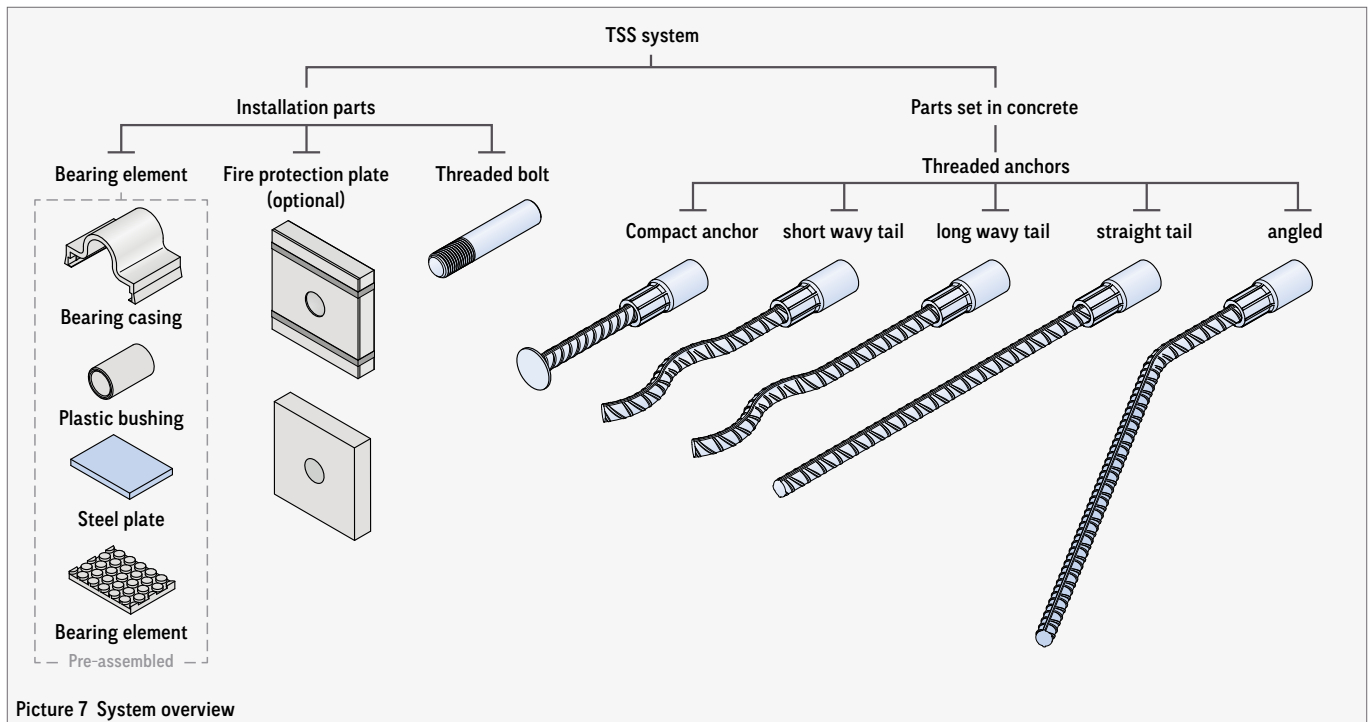

Picture 7 System overview

TABLE 1: SYSTEM OVERVIEW

Bearing element		Installation parts		Parts set in concrete
Ref. no.	Bearing element	Fire protection plate (optional)	Threaded bolt	Threaded anchors
<b>Indoor (galvanised version)</b>				
67TSEN-CIP	Cipremont®	74BSM____-36, 67TSBMN020, 67TSBMN030, 67TSBMN050,	670TSSN____ST, 670TSSN____8	67TSS360235, 67M36WE, 67M36K, 67M36, 67M361100, 67M360732GE45
67TSEN-S65	Compact bearing			
<b>Outdoor (stainless steel version)</b>				
67TSENVA-CIP	Cipremont®	74BSM____-36, 67TSBMN020, 67TSBMN030, 67TSBMN050,	670TSSN____VA	75TSS360235VA, 75M36VAWE, 75M36VAK, 75M36VA, 75M361100VA, 75M360732VAGE45
67TSENVA-S65	Compression bearing			

# Bearing system with noise reduction TSS

## INSTALLATION PARTS

TABLE 2: BEARING ELEMENT

Ref. no.	Dimensions				Elastomeric bearing (115 × 82.5 mm)	Steel plate (110 × 80 mm)
	b (mm)	t (mm)	h (mm)	h <sub>A</sub> (mm)		
<b>Galvanised version</b>						
67TSEN-CIP	132	88	76	45	Cipremont®	Bright zinc plated
67TSEN-S65					Compression bearing	
<b>Stainless steel version</b>						
67TSENVA-CIP	132	88	76	45	Cipremont®	Stainless steel
67TSENVA-S65					Compression bearing	

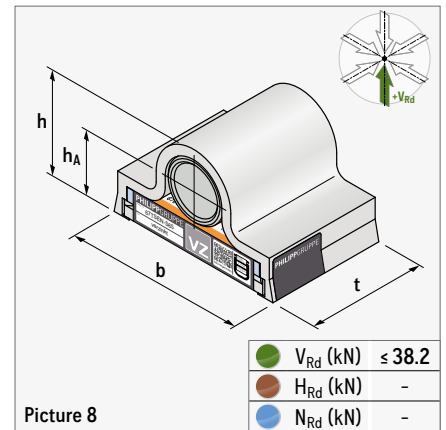

Picture 8

In order to identify the different bearing elements these are marked with the following information:

- » Manufacturer
- » Ref. no. (e.g. 67TSEN-S65)
- » Type (e.g. galvanised) including coloured marking (VZ/VA)
- » QR code for this Installation Instruction
- » Ü sign
- » Installation instructions on the bottom side

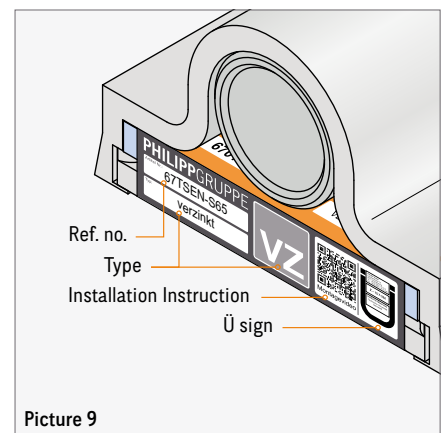

Picture 9

TABLE 3: THREADED BOLT

Ref. no.	Thread M	e (mm)	L <sub>B</sub> (mm)
<b>S355 galvanised (marking ST)</b>			
670TSSN160ST	M36	56	160
670TSSN170ST			170
670TSSN180ST			180
670TSSN190ST			190
670TSSN200ST			200
670TSSN210ST			210
670TSSN220ST			220
<b>Tempered steel (marking 8)</b>			
670TSSN1608	M36	56	160
670TSSN1708			170
670TSSN1808			180
670TSSN1908			190
670TSSN2008			200
670TSSN2108			210
670TSSN2208			220
<b>Stainless steel S460 (marking VA)</b>			
670TSSN160VA	M36	56	160
670TSSN170VA			170
670TSSN180VA			180
670TSSN190VA			190
670TSSN200VA			200
670TSSN210VA			210
670TSSN220VA			220

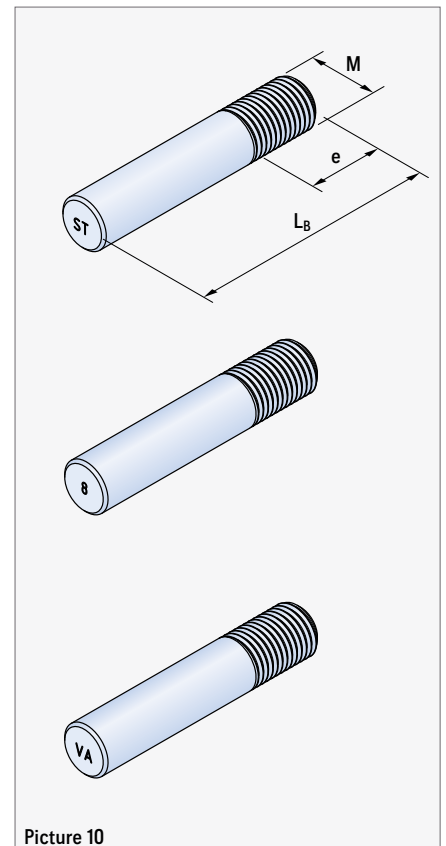

Picture 10

## PARTS SET IN CONCRETE

TABLE 4: COMPACT ANCHOR

Ref. no.	Thread	ØD	ØD <sub>1</sub>	L	Ød <sub>s</sub>
	RD	(mm)	(mm)	(mm)	(mm)
<b>Galvanised version</b>					
67TSS360235	36	47	60	235	25
<b>Stainless steel version</b>					
75TSS360235VA	36	50	60	235	25

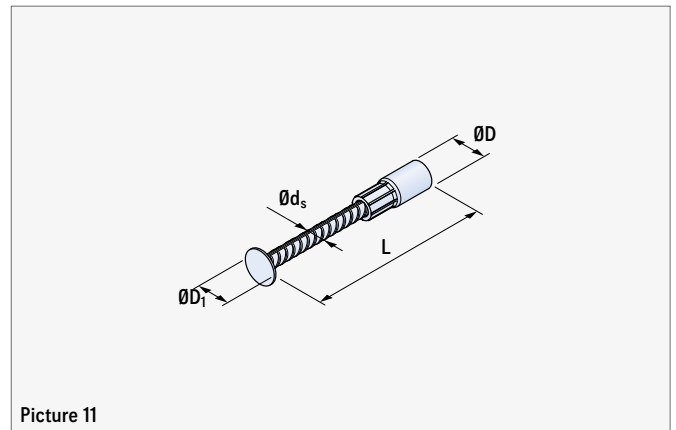

Picture 11

TABLE 5: THREADED ANCHORS (SHORT AND LONG WAVY TAIL)

Ref. no.	Thread	ØD	L <sup>①</sup>	Ød <sub>s</sub>
	RD	(mm)	(mm)	(mm)
<b>Galvanised version</b>				
67M36K	36	47	380	25
67M36WE	36	47	570	25
<b>Stainless steel version</b>				
75M36VAK	36	50	380	25
75M36VAWE	36	50	570	25

① The short anchor length L is sufficient to guarantee the bearing capacity. Longer anchors are possible.

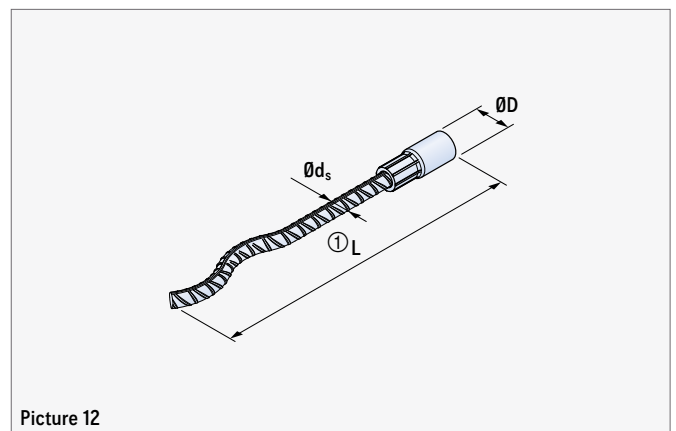

Picture 12

TABLE 6: THREADED ANCHOR (STRAIGHT TAIL) ②

Ref. no.	Thread	ØD	L <sup>①</sup>	Ød <sub>s</sub>
	RD	(mm)	(mm)	(mm)
<b>Galvanised version</b>				
67M36	36	47	690	25
67M361100	36	47	1100	25
<b>Stainless steel version</b>				
75M36VA	36	50	690	25
75M361100VA	36	50	1100	25

① The short anchor length L is sufficient to guarantee the bearing capacity. Longer anchors are possible.

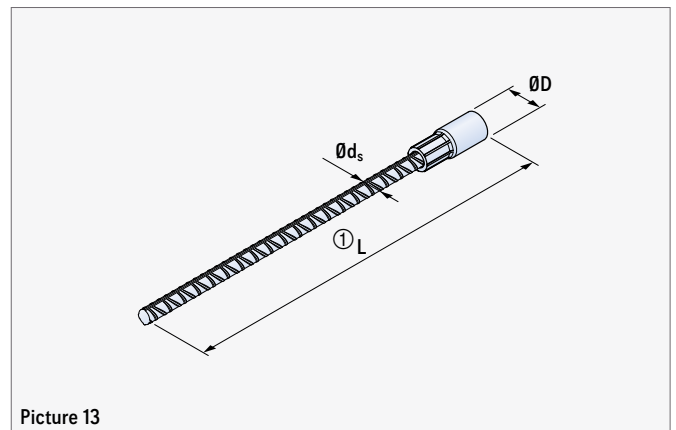

Picture 13

TABLE 7: THREADED ANCHOR (45° ANGLED) ②

Ref. no.	Thread	ØD	Ød <sub>s</sub>	a	l <sub>a</sub>	w <sub>b</sub>
	RD	(mm)	(mm)	(mm)	(mm)	(°)
<b>Galvanised version</b>						
67M360732GE45	36	47	25	165	690	45
<b>Stainless steel version</b>						
75M360732VAGE45	36	50	25	165	690	45

② Anchors are suitable for bending by the user. (refer to the notes on page 17)

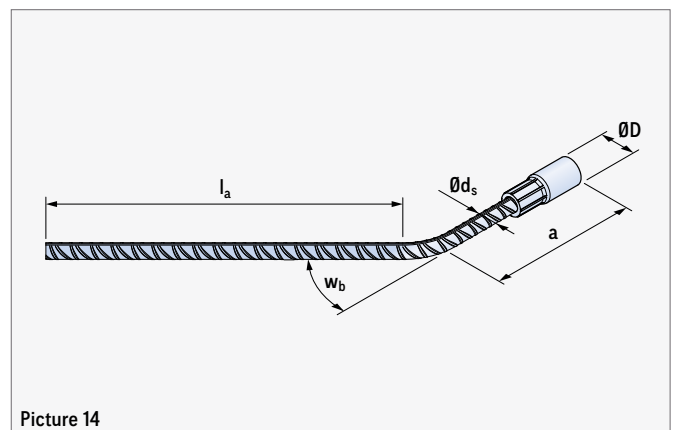

Picture 14

# Bearing system with noise reduction TSS

## INSTALLATION INSTRUCTIONS

### INSTALLATION OPTIONS

Following installation options are possible for the TSS system.

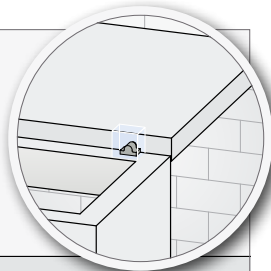

**Compact anchor**

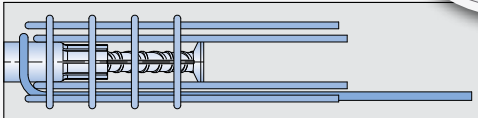

67TSS360235;  
75TSS360235VA

**Threaded anchor - short wavy tail**

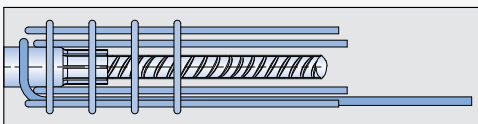

67M36K;  
75M36VAK

**Threaded anchor - long wavy tail**

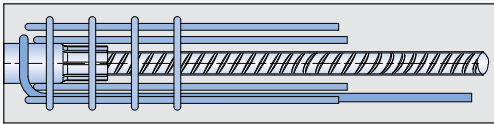

67M36WE;  
75M36VAWE

**Threaded anchor - straight tail**

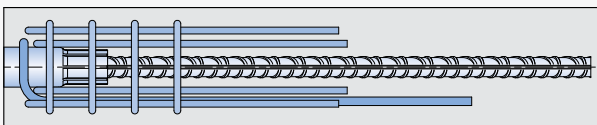

67M36; 67M361100;  
75M36VA; 75M361100VA

Picture 15

**Threaded anchor - angled**

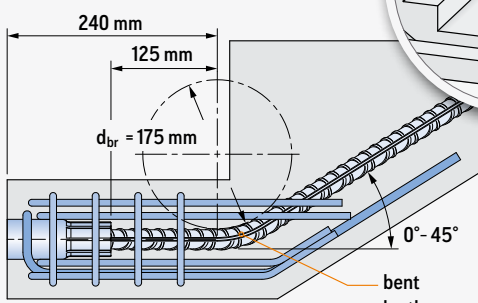

240 mm  
125 mm  
 $d_{br} = 175 \text{ mm}$   
0°-45°  
bent by the user

67M36; 67M361100;  
75M36VA; 75M361100VA

**Compact anchor**

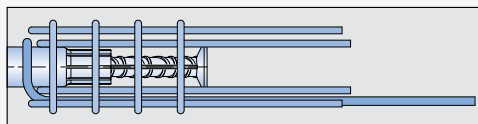

67TSS360235;  
75TSS360235VA

**Threaded anchor - 45° angled**

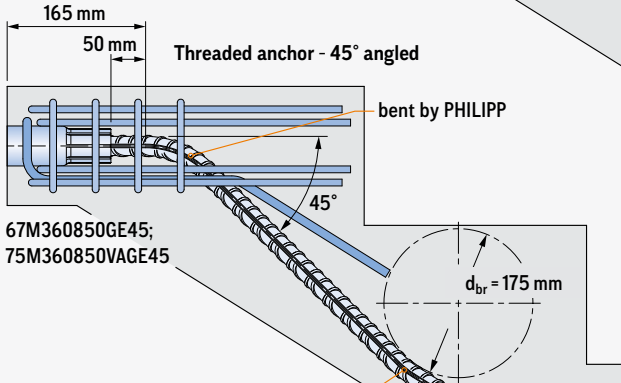

165 mm  
50 mm  
bent by PHILIPP  
45°  
 $d_{br} = 175 \text{ mm}$   
offset by the user

67M360850GE45;  
75M360850VAGE45

**Threaded anchor - angled**

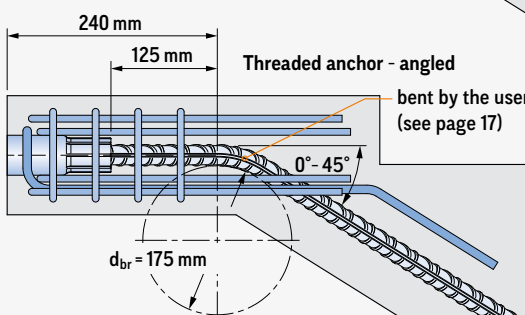

240 mm  
125 mm  
bent by the user (see page 17)  
0°-45°  
 $d_{br} = 175 \text{ mm}$

67M36; 67M361100;  
75M36VA; 75M361100VA

Picture 16

## INSTALLATION INSTRUCTIONS

### ELEMENT DIMENSIONS

Table 8 specifies element thicknesses, distances, bracket widths and depths attention have to be paid to. The anchor should be installed centred in the reinforced concrete element relating to the element thickness ( $d/2$ ). If the anchor is installed in a bracket, it shall be placed in the centre of the bracket ( $b_k/2$ ). Attention has to be paid to a careful and exact installation.

If a FEM calculation is necessary to find out the support reactions, the spring stiffnesses has to be considered. For more information about the spring stiffnesses please refer to picture 21. The structural engineer has to prove the load transfer of the support reactions.

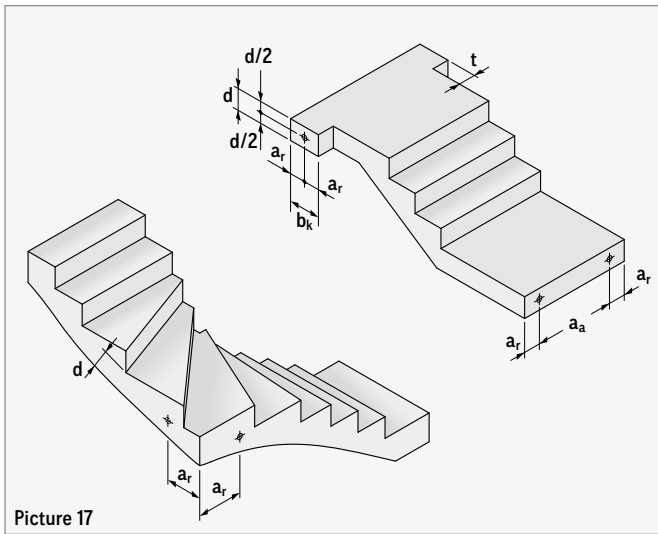

Picture 17

TABLE 8: CONCRETE ELEMENT DIMENSIONS

Minimum element thickness $d$ (mm)	Minimum edge distance $a_r$ (mm)	Minimum centre distance $a_a$ (mm)	Minimum bracket width $b_k$ (mm)	Maximum bracket depth $t$ (mm)
$\geq 140$ ①②	$\geq 100$	$\geq 200$	$\geq 200$	$\leq 150$

- ① In case of fire protection requirements, higher component thicknesses may be required.
- ② With a given minimum element thickness of 140 mm the concrete cover is  $c_{nom} = 15$  mm and the minimum concrete strength C20/25. If the exposure class requires a higher concrete cover, the minimum element thickness shall be increased (picture 24).

### CALCULATION OF THE BOLT LENGTH

The installation distance results from the addition of the bearing edge distance and the given wall distance ( $m \geq A_l + A_w$ ). Here, structural tolerances of the building side have to be considered. Then, the bolt length is to be selected from table 9. Handtight and completely into the anchor the threaded bolt is screwed. A tightening torque must not be applied here. Finally, the bearing element is pushed onto the bolt until the back plane touches the end of the bolt. For the specification of the bearing edge distance  $A_l$  (picture 18) the structural engineer is responsible.

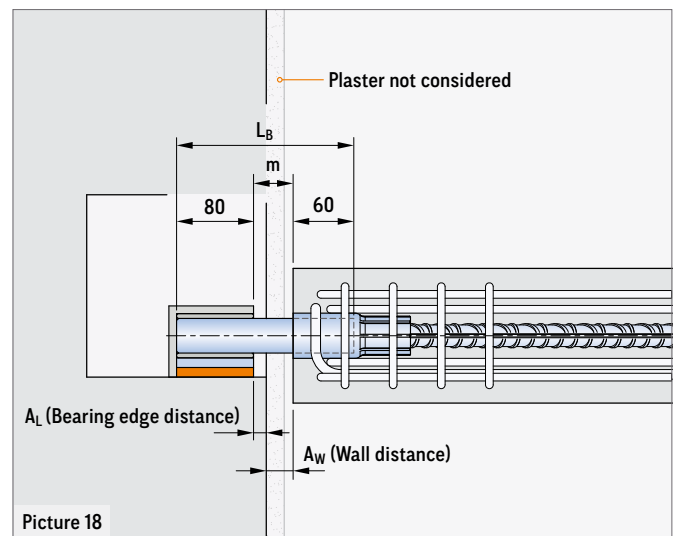

Picture 18

TABLE 9: INSTALLATION DISTANCES

Installation distance max. $m$ (mm)	Bolt length min. $L_B$ (mm)
20	160
30	170
40	180
50	190
60	200
70	210
80	220



### LIFTING OF THE CONCRETE ELEMENTS

A lifting of the precast concrete elements with the threaded anchors of the impact sound insulation system is not permitted.

# Bearing system with noise reduction TSS

## DESIGN / BEARING CAPACITIES OF THE SYSTEM

For predominantly static loads the TSS system is designed for. The allowed load bearing capacities vary depending on the mounting distance  $m$  (picture 19) and the material of the threaded bolt (Table 10). Here, the mounting distance is defined as the distance of the threaded anchor in the concrete element to the front edge of the bearing element (picture 18 and 19). If the threaded anchor is fixed to the formwork using a plastic, magnetic or steel Nailing plate the mounting distance  $m$  has to be increased by the depth of the recess. The concrete quality of the element to be borne can be chosen from C20/25 to C50/60 with regard to the strength class. The load bearing capacity shall be verified with  $V_{Ed} / V_{Rd} \leq 1.0$ .

For each individual case the transfer of the loads to the bearings of the adjacent components shall be verified for the ultimate limit state and the serviceability limit state. If the bearing element is used in masonry wall, the action effects shall be verified in accordance with EN 1996-1-1.

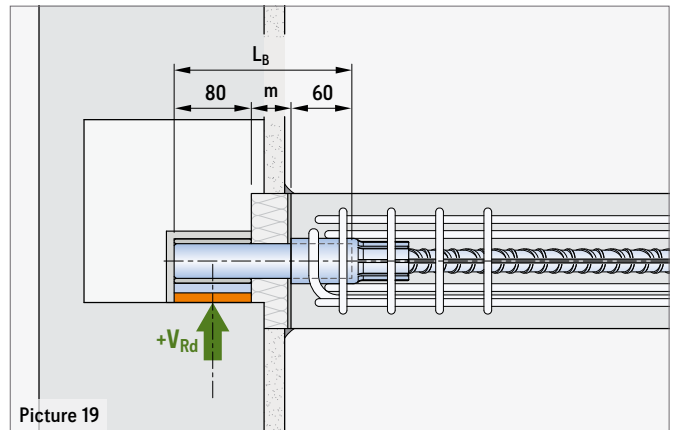

Picture 19



### FURTHER REGULATIONS

Further regulations for planning, design and installation can be found in the German approval (Z-15 7-332).

TABLE 10: LOAD BEARING CAPACITIES DEPENDING ON THE MOUNTING DISTANCE

Ref. no.	Bolt length ① $L_B$ (mm)	Mounting distance ① $m$ (mm)	$+V_{Rd}$ (kN)
<b>S355 galvanised (marking ST)</b>			
670TSSN160ST	160	20	24.8
670TSSN170ST	170	30	21.3
670TSSN180ST	180	40	18.6
670TSSN190ST	190	50	16.5
670TSSN200ST	200	60	14.9
670TSSN210ST	210	70	13.5
670TSSN220ST	220	80	12.4
<b>Tempered steel (marking 8)</b>			
670TSSN1608	160	20	38.2
670TSSN1708	170	30	36.1
670TSSN1808	180	40	33.9
670TSSN1908	190	50	31.8
670TSSN2008	200	60	29.7
670TSSN2108	210	70	27.5
670TSSN2208	220	80	25.4
<b>Stainless steel S460 (marking VA)</b>			
670TSSN160VA	160	20	28.0
670TSSN170VA	170	30	24.0
670TSSN180VA	180	40	21.0
670TSSN190VA	190	50	18.7
670TSSN200VA	200	60	16.8
670TSSN210VA	210	70	15.3
670TSSN220VA	220	80	14.0

① For more information about the bolt length  $L_B$  and mounting distance  $m$  refer to page 13 (Calculation of the bolt length)

## IMPACT SOUND

The application of the TSS system ensures the impact sound protection recommended by the German standard DIN 4109. Compared to conventional bearings the TSS system achieves a considerable reduction of impact sound. For the different types of the TSS system the determined impact sound reduction is given in table 11 as a function of the actual bearing element and an increasing support reaction. All values of the impact sound reduction are results from tests done by the notified body ITA ("Ingenieurgesellschaft für Technische Akustik mbH") in Germany based on DIN EN ISO 10140 and DIN 7396.

With the amendment of the standards and the introduction of further requirements new terms and characteristic values are available for the assessment of impact sound products. The test setup for impact sound elements is given in DIN 7396 and is used to compare the acoustic quality of different products. An important parameter here is the impact sound level difference  $\Delta_{L^*n,w}$ .

These characteristic values were determined gradually for stairs and landings between the minimum and maximum dead weight loads. All values of the impact sound pressure level reduction only apply to the detailed verification procedure in accordance with DIN EN ISO 1234-2.

TABLE 11: NOISE REDUCTION CAPACITY ACCORDING DIN 7396

Element	Weighted impact sound pressure level $\Delta_{L^*n,w} (C_i, \Delta)^*1$ [dB]
<b>67TSEN-CIP / 67TSEN-CIP (Cipremont®)</b>	
Landing	31 - 21
<b>67TSEN-S65/ 67TSENVA-S65 (Cipremont)</b>	
Landing	29 - 17

## SPRING STIFFNESS

If a FEM calculation is required to determine the support reactions the spring stiffness according to picture 20 or 21 is to be used for each individual support.



## TEST REPORTS

For more information have a look to the ITA test reports.

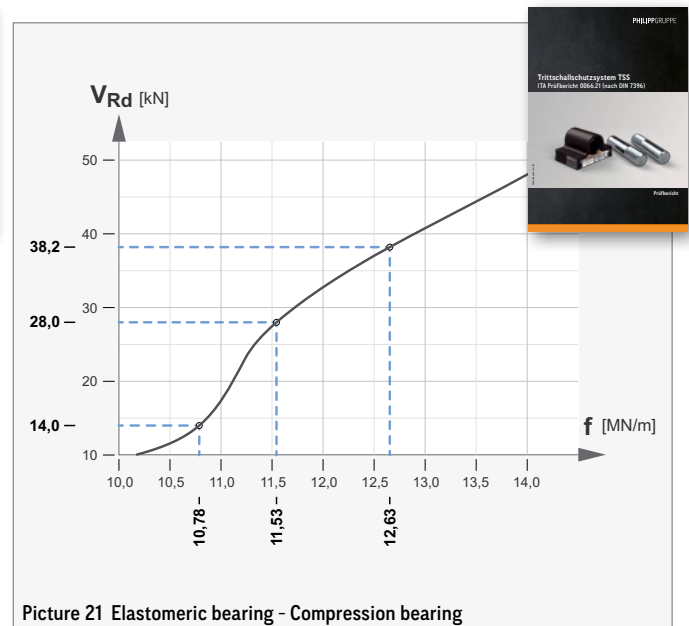
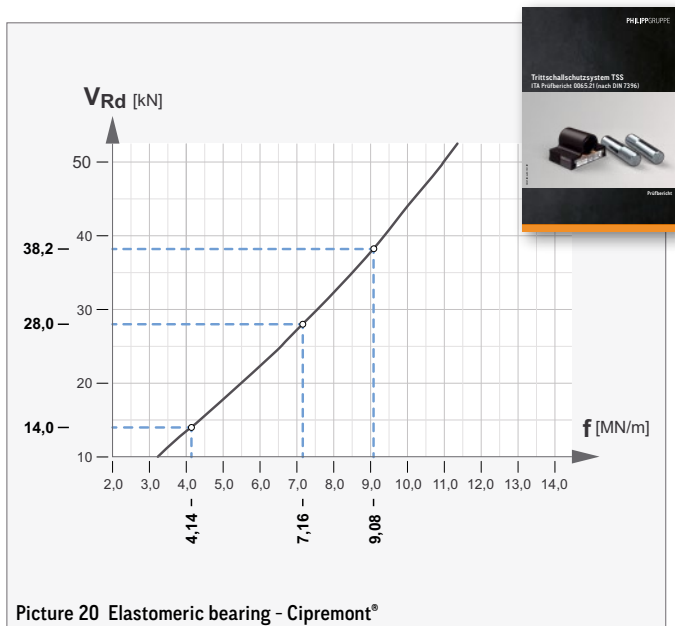

# Bearing system with noise reduction TSS

## REINFORCEMENT (PROOF OF LOCAL LOAD TRANSFER PROVIDED)

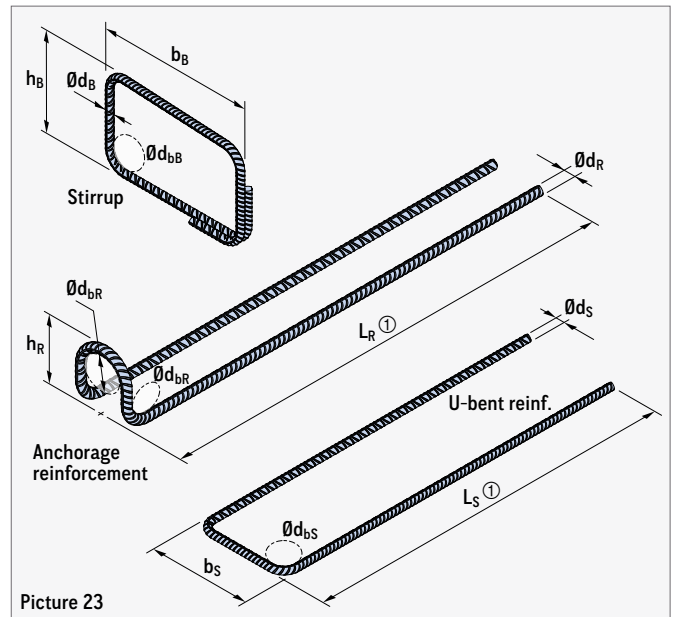
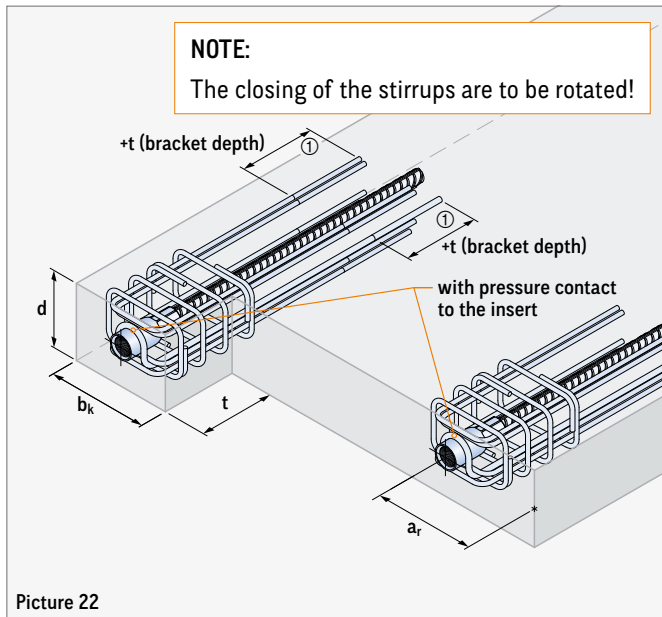

Shown reinforcement made of B500A/B/NR ensures the local load transfer without further calculations and additional reinforcement. The reinforcement can be used in slabs as well as in elements with integrally moulded brackets. All element dimensions given in table 8 shall be observed. Either the anchorage or the lapping of the U-bent reinforcement and the anchor stirrup shall be considered.

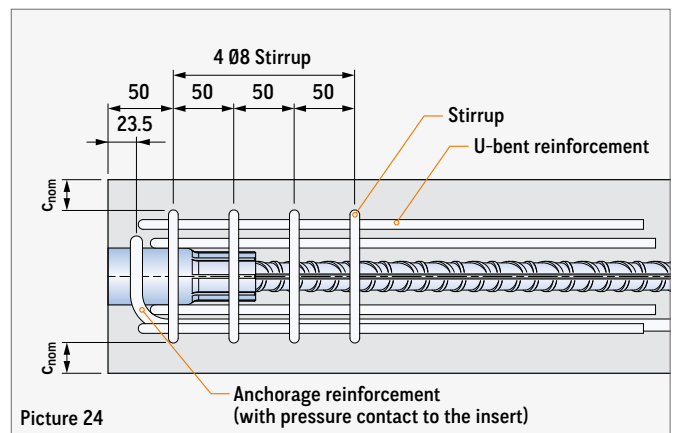

TABLE 12: REINFORCEMENT (B500A/B)

Number (pcs.)	Anchor stirrup				Number (pcs.)	Stirrup				Number (pcs.)	U-bent reinforcement			
	Ød <sub>R</sub> (mm)	h <sub>R</sub> (mm)	L <sub>R</sub> ① (mm)	Ød <sub>bR</sub> (mm)		Ød <sub>B</sub> (mm)	h <sub>B</sub> (mm)	b <sub>B</sub> (mm)	Ød <sub>bB</sub> (mm)		Ød <sub>S</sub> (mm)	b <sub>S</sub> (mm)	L <sub>S</sub> ① (mm)	Ød <sub>bS</sub> (mm)
1	Ø 10	≥ 75	≥ 500	Ø 48	4	Ø 8	≥ 110	≥ 170	Ø 32	4	Ø 8	120	≥ 400	Ø 32

① With brackets the length L<sub>R</sub> of the anchor stirrup and L<sub>S</sub> of the U-bent reinforcement must be increased by the bracket depth t.



## BENDING OF THREADED ANCHORS

### BENDING OF THREADED ANCHORS BY THE USER

The bending of threaded anchors requires a minimum distance to the socket, at least 5 times of the rebar diameter (125 mm). If the anchor is already bent by PHILIPP, this dimension can be reduced to 2 times of the rebar diameter. The mantrel diameter  $d_{br}$  must be at least 7 times of the rebar diameter (175 mm). If the threaded anchor is bent a deformation of the crimped-on socket must be avoided (picture 26).

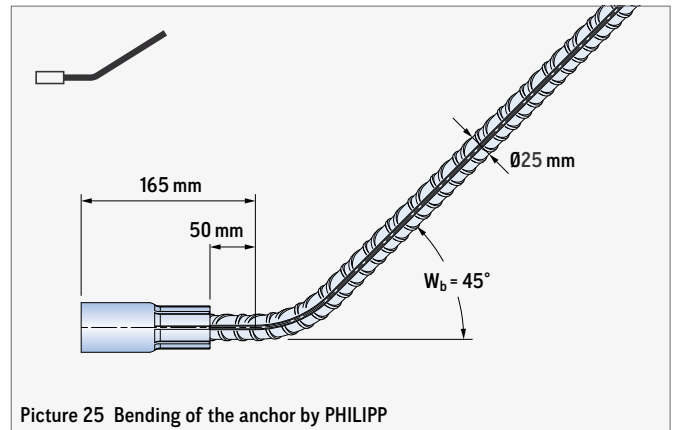

Picture 25 Bending of the anchor by PHILIPP

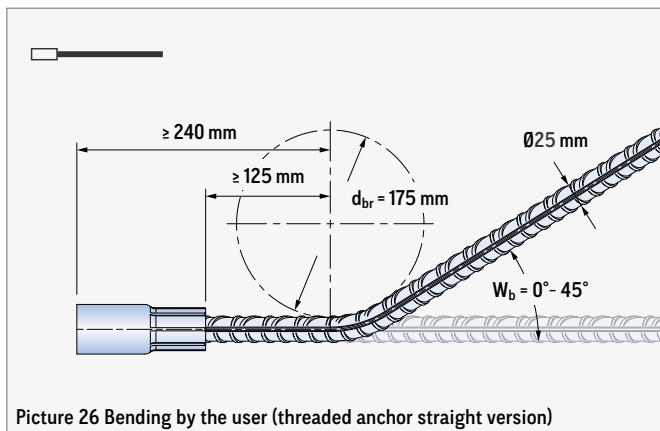

Picture 26 Bending by the user (threaded anchor straight version)

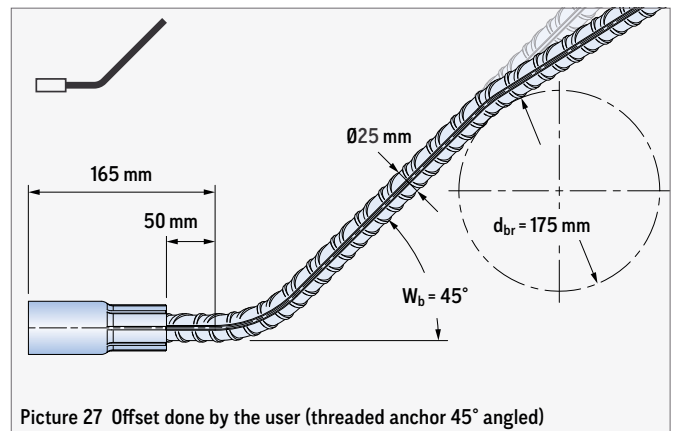

Picture 27 Offset done by the user (threaded anchor 45° angled)

# Bearing system with noise reduction TSS

## FIRE PROTECTION PLATE (R120)

This fire protection plate is made of high-compressed rock wool and a one-sided intumescent coating. With appropriate component thicknesses, it enables the fire resistance class REI 120-RF1 (non-combustible, A1) according to EN 13501-2 based on the EMPA fire test and fire protection report ETH No. 2019-08-001. From thickness 20 to 100 mm this fire protection plate is available. It must be placed with slight pressure load on both sides to the final installation position close to both elements.

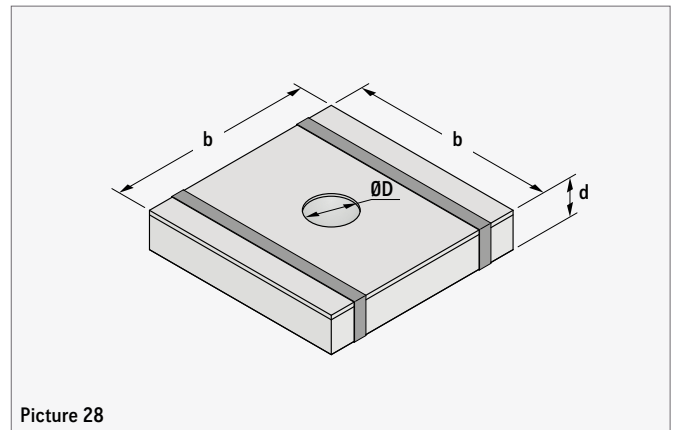

Picture 28

TABLE 13: FIRE PROTECTION PLATE

Ref. no.	ØD (mm)	d (mm)	b (mm)
74BSM020-36	36	20	160
74BSM030-36	36	30	160
74BSM040-36	36	40	160
74BSM050-36	36	50	160
74BSM060-36	36	60	160
74BSM070-36	36	70	160
74BSM080-36	36	80	160
74BSM090-36	36	90	160
74BSM100-36	36	100	160



### TEST REPORT

For more information about fire protection please refer to the test report.



## INSTALLATION

The fire protection plate is pushed onto the fully screwed-in threaded bolt. Pay attention during the actual installation of the TSS that the bearing element is pushed onto the bolt until the back plane touches the end of the bolt. Depending on the dimension of the bearing edge distance it might be necessary to cut the fire protection plate in the bearing area.

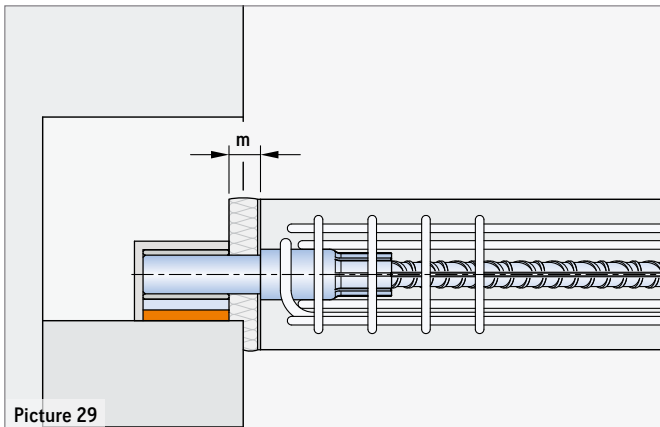

Picture 29

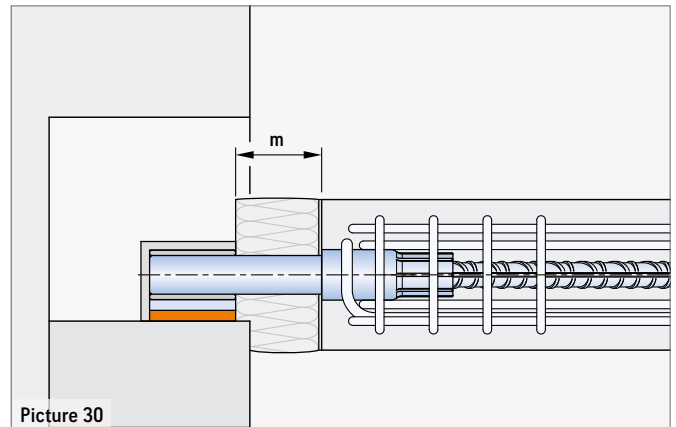

Picture 30

## FIRE PROTECTION PLATE (F90)

The TSS fire protection plate meets the requirements of the fire protection expert opinion for non-flammable mineral wool. It guarantees the fire resistance class F90 according to the German DIN 4102-2 when the edge distances specified in table 8 are observed. The fire protection plate consists of a jacketed mineral wool core and is available in thicknesses of 20, 30 and 50 mm. It must be placed with slight pressure load on both sides to the final installation position close to both elements.



### TEST REPORT

For more information about fire protection please refer to the test report.

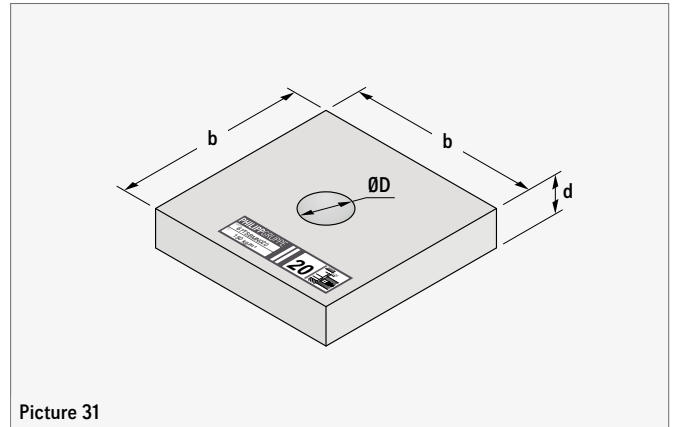

Picture 31

TABLE 14: FIRE PROTECTION PLATE

Ref. no.	Type (kg/m <sup>3</sup> )	ØD (mm)	d (mm)	b (mm)
67TSBMN020	150	36	20	150
67TSBMN030	150	36	30	150
67TSBMN050	150	36	50	150

### INSTALLATION

The fire protection plate is pushed onto the fully screwed-in threaded bolt. In order to cover installation distances from 30 mm up to 80 mm with the plate, it is possible to combine plates of both thicknesses. Pay attention during the actual installation of the TSS that the bearing element is pushed onto the bolt until the back

plane touches the end of the bolt. Depending on the dimension of the bearing edge distance it might be necessary to cut the fire protection plate in the bearing area.

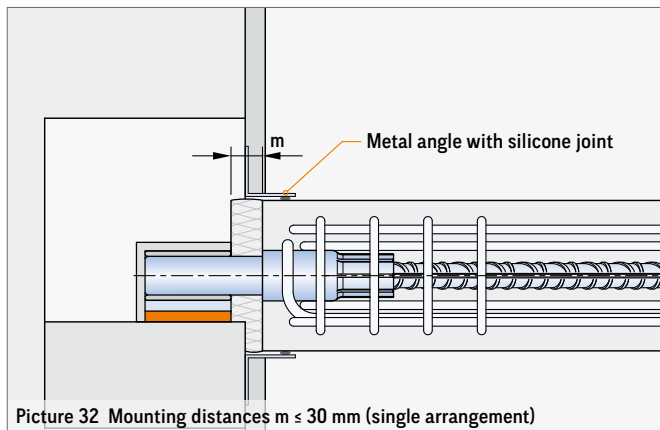

Picture 32 Mounting distances  $m \leq 30$  mm (single arrangement)

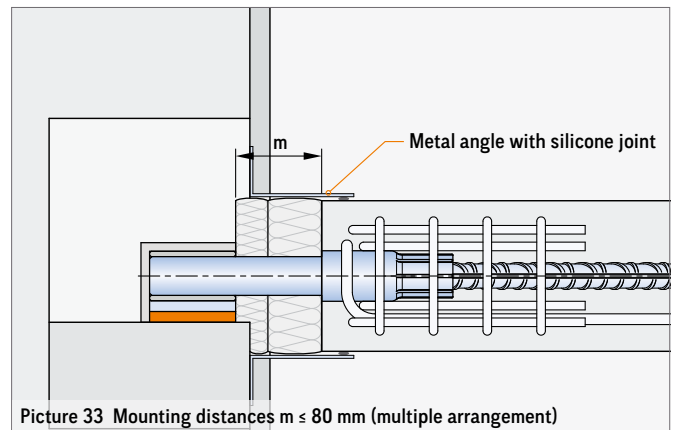

Picture 33 Mounting distances  $m \leq 80$  mm (multiple arrangement)

# Bearing system with noise reduction TSS

## INSTALLATION OF THE BEARING SYSTEM WITH NOISE REDUCTION TSS

During installation, the threaded bolt is completely screwed into the socket by hand through a recess in the wall. Naturally, the block-out in the wall has to be adapted to the requirements given at the job-site. Guiding values are given in the following pictures. Then, the bearing element is completely pushed onto the bolt screwed-in. A mortar bed, the bearing element is placed on, levels minor irregularities. Also possible is to take steel plates in order to

achieve a uniform level of support. In any case the bearing element must always be in full contact with the base. A grouting of the previously created block-out is necessary to ensure a long-lasting bearing. Here, attention has to be paid not to create acoustic bridges during grouting.

If the fire protection plate is used, it shall be pushed onto the bolt first, then the bearing element follows.

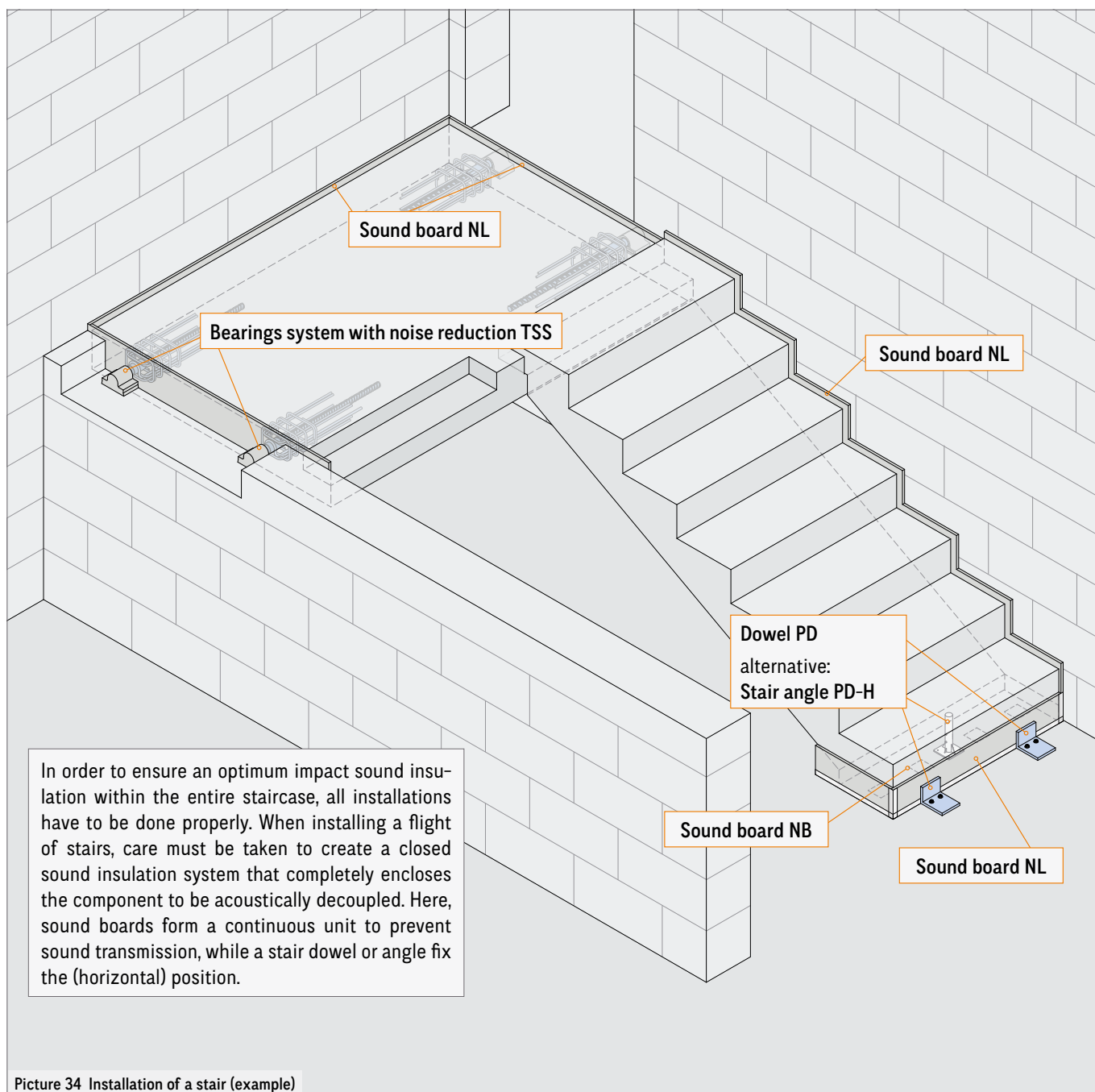

# INSTALLATION OF THE BEARING SYSTEM WITH NOISE REDUCTION TSS

## INSTALLATION IN THE PRECAST ELEMENT

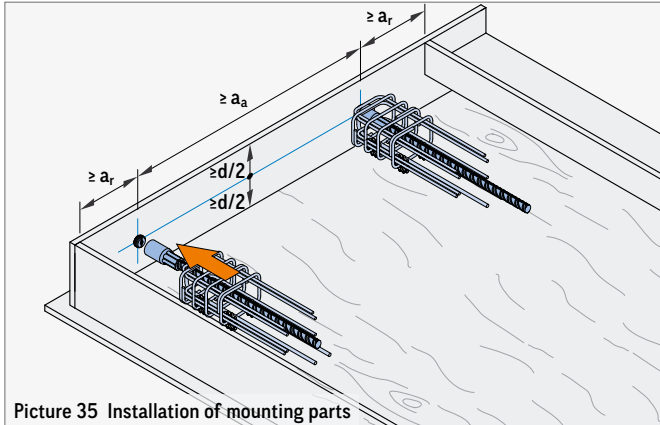

Picture 35 Installation of mounting parts

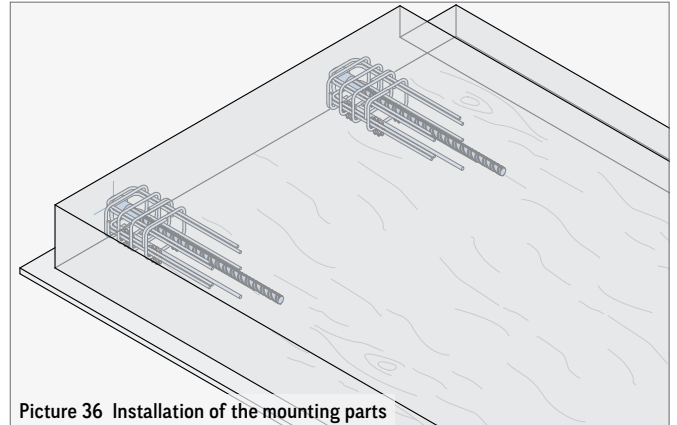

Picture 36 Installation of the mounting parts



### TRANSPORT OF THE PRECAST ELEMENTS

- » The bearing elements must not be pushed on the screwed-in threaded bolt during transport of the concrete elements.
- » A lifting of the precast concrete elements with the threaded anchors of the impact sound insulation system is not permitted.

## INSTALLATION OF THE BEARING ELEMENT

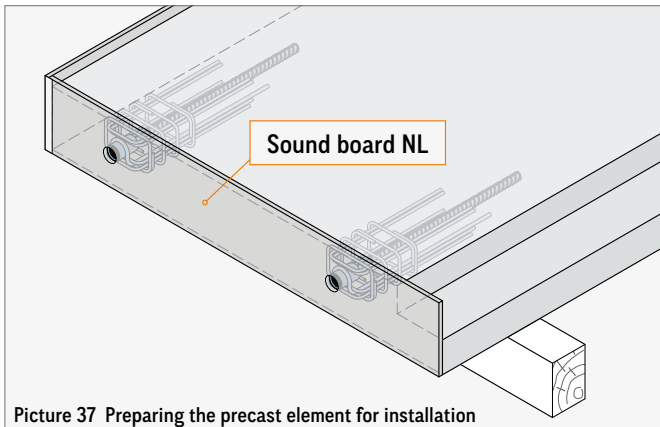

Picture 37 Preparing the precast element for installation

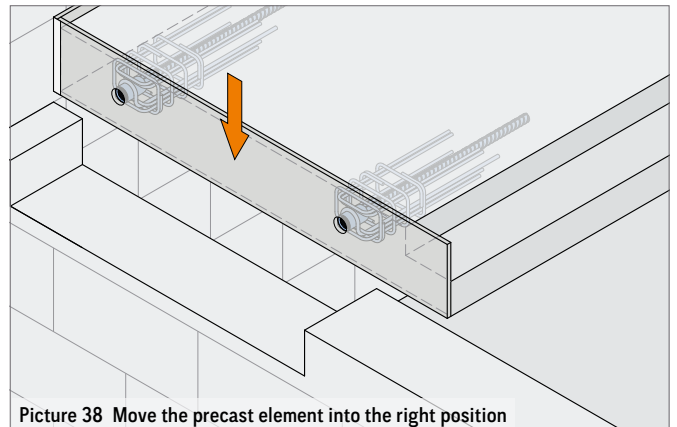

Picture 38 Move the precast element into the right position

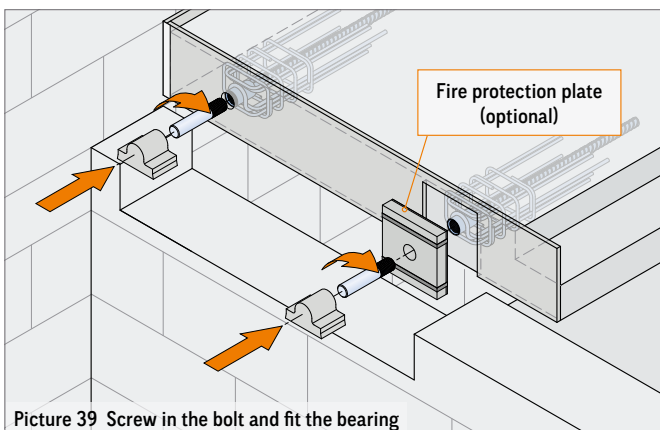
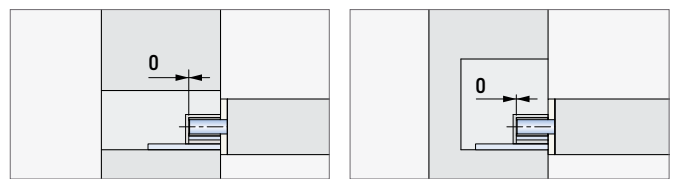

Picture 39 Screw in the bolt and fit the bearing

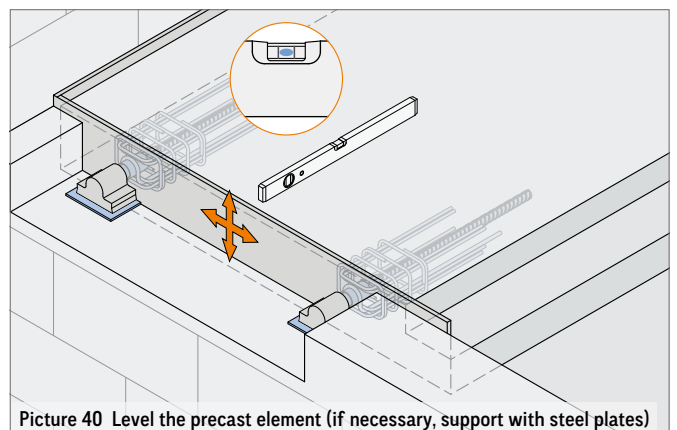

Picture 40 Level the precast element (if necessary, support with steel plates)

# Bearing system with noise reduction TSS

## INSTALLATION OF THE BEARING SYSTEM WITH NOISE REDUCTION TSS

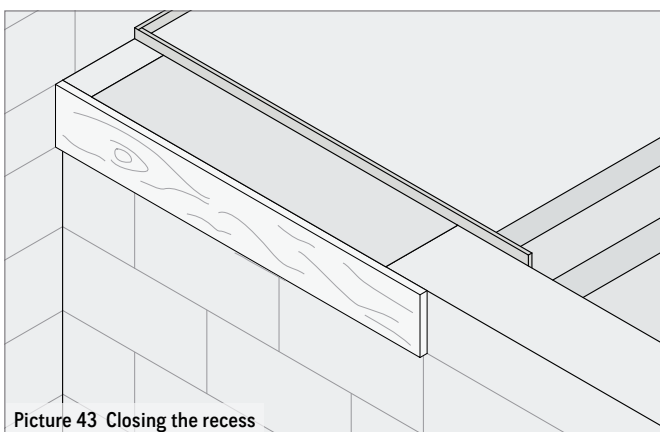
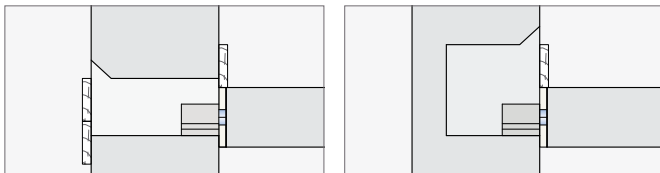
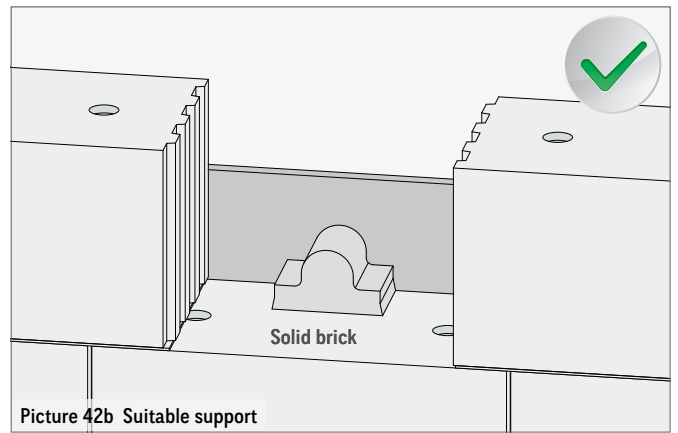
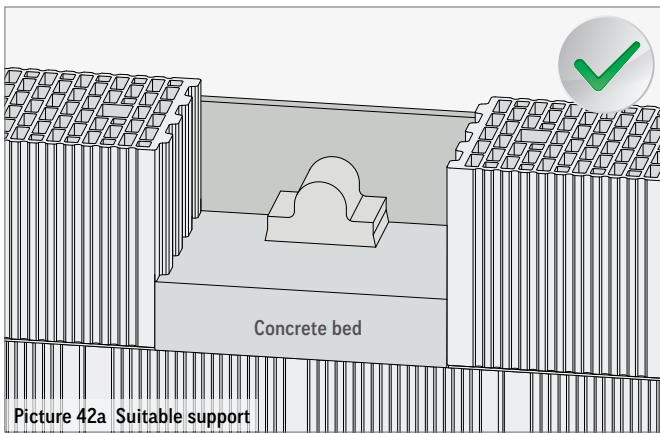
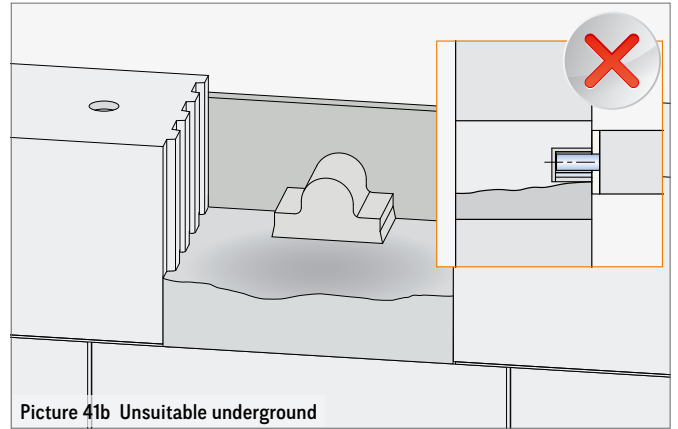
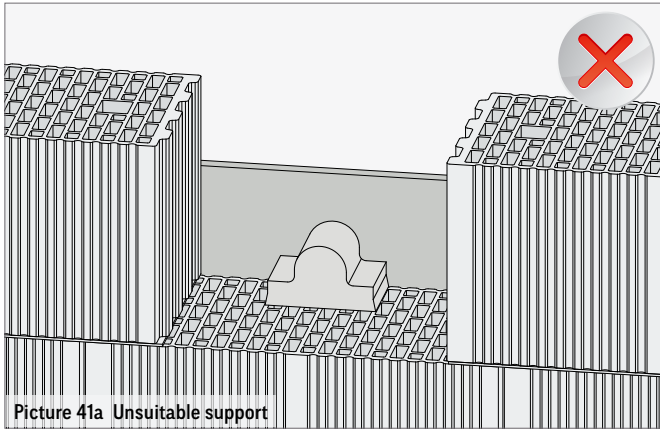

### COMPRESSION STRENGTHS OF THE SUPPORT

A suitable support for the bearing is mandatory. The required compressive strength must be determined and verified by a structural engineer.

## NOTES

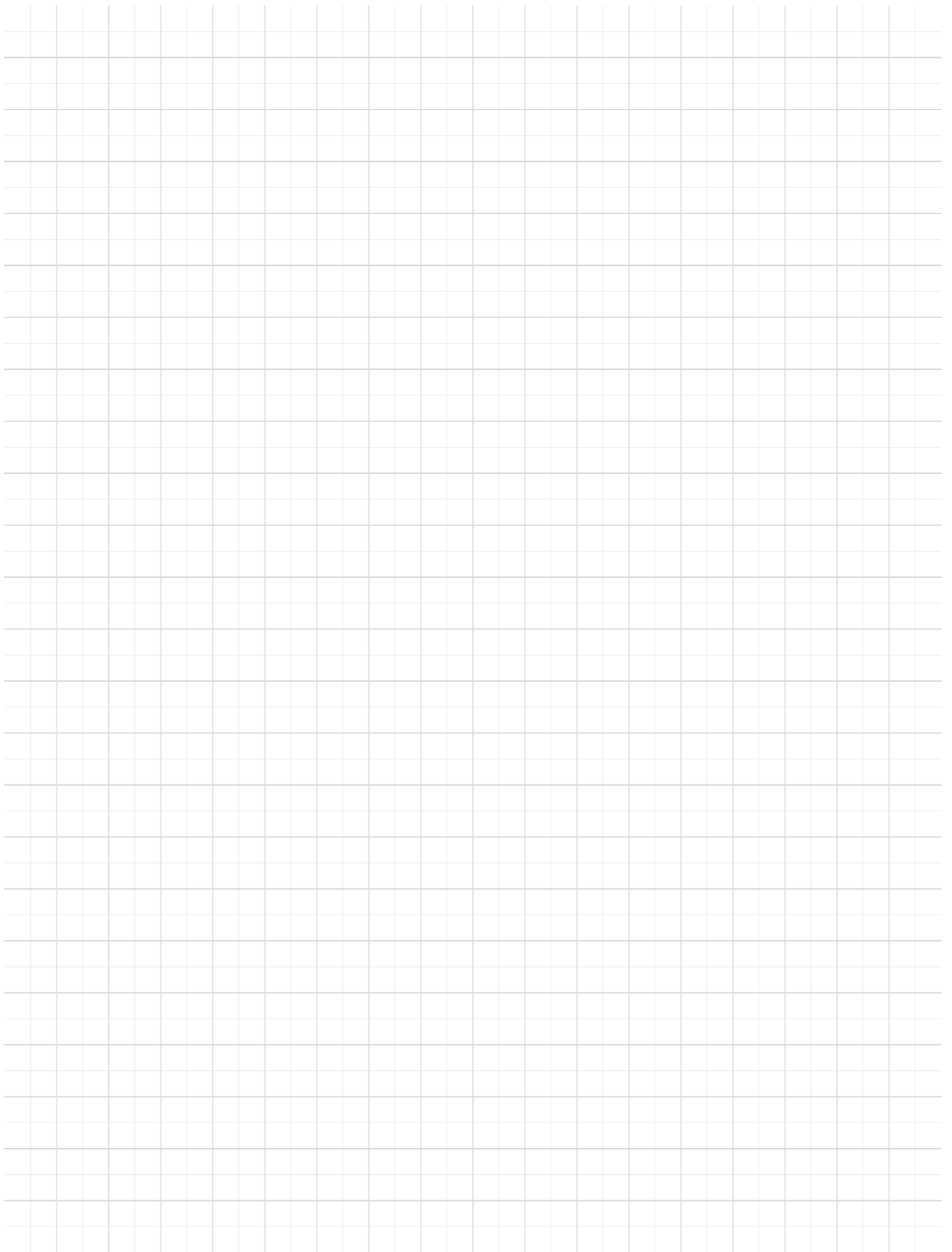

## HEADQUARTERS

Lilienthalstraße 7-9  
63741 Aschaffenburg  
☎ +49 6021 40 27-0  
✉ info@philipp-gruppe.de

## PRODUCTION AND LOGISTICS

Hauptstraße 204  
63814 Mainaschaff  
☎ +49 6021 40 27-0  
✉ info@philipp-gruppe.de

## OFFICE COSWIG

Roßlauer Straße 70  
06869 Coswig / Anhalt  
☎ +49 34903 6 94-0  
✉ info@philipp-gruppe.de

## OFFICE NEUSS

Sperberweg 37  
41468 Neuss  
☎ +49 2131 3 59 18-0  
✉ info@philipp-gruppe.de

## OFFICE TANNHEIM

Robert-Bosch-Weg 12  
88459 Tannheim / Allgäu  
☎ +49 8395 8 13 35-0  
✉ info@philipp-gruppe.de

## PHILIPP VERTRIEBS GMBH

Pfaffing 36  
5760 Saalfelden / Salzburg  
☎ +43 6582 7 04 01  
✉ info@philipp-gruppe.at



HEADQUARTERS Aschaffenburg



Visit us! [www.philipp-gruppe.de](http://www.philipp-gruppe.de)